

# Pixhawk 4 Mini QAV250 Kit

## Quick Start Guide

### Tools Needed

- 2.0mm Hex screwdriver
- #0 Phillips screwdriver
- Wire cutters
- Precision tweezers

### Required Components

- QAV250 Basic or Complete Kit
- RC receiver and compatible transmitter
- Battery - 4s 1300mah

### Figure 1 - Kit Parts



- |                            |                                |  |
|----------------------------|--------------------------------|--|
| 1. Mid Plate               | 8. Propellers                  | 15. Micro Telemetry Radio                                |
| 2. Top Plate               | 9. Motor x 4                   | 16. Foxeer FPV Camera*                                   |
| 3. Bottom Plate            | 10. GPS                        | 17. Cables   |
| 4. Flight Controller Plate | 11. Pixhawk 4 Mini             | 18. Foam Pads  |
| 5. Landing Leg x 4         | 12. Battery Straps             | 19. Power Distribution Board - fully assembled with ESCs |
| 6. Arm x 4                 | 13. Atlatl HV FPV Transmitter* |  |
| 7. Frame Hardware          | 14. Telemetry Radio            |  |

### Figure 2

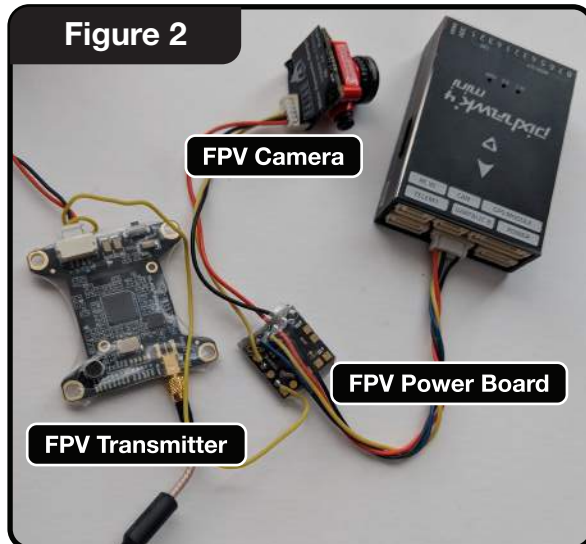

### Figure 3

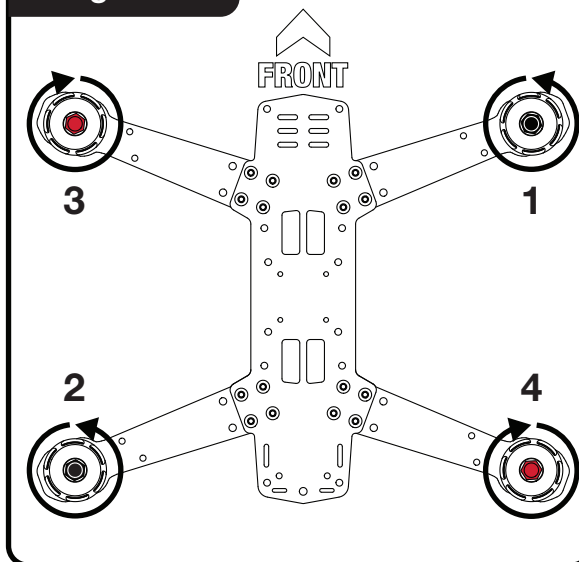

### 1

- Mid Plate
- Bottom Plate
- Arm x 4
- Steel M3 12mm Screw x 16
- Steel M3 Locknut x 16
- Plastic M3 Button Head Screw x 4
- Plastic M3 Nut x 4

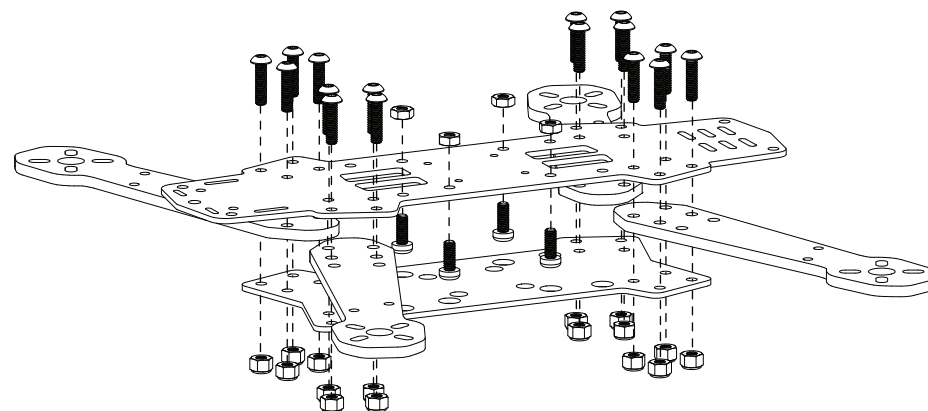

### 2

- a** Attach the motors as shown in Figure 3. Note the color of the propeller nuts. **Tighten screws firmly.**
- b** Attach Landing Legs by sliding them up the arms until they are secure.

- Steel M3 Motor Screw x 16 (Found with motors)
- Motor x 4
- Landing Leg x 4

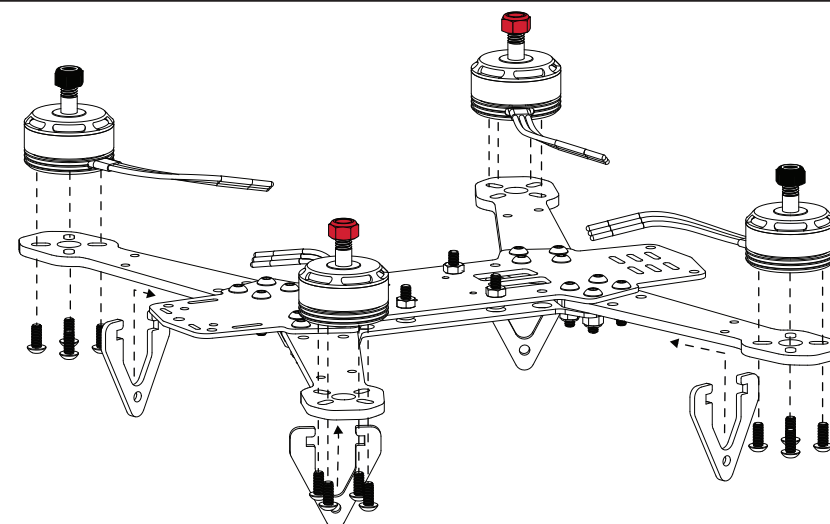

### 3

Place and fasten down Power Distribution Board (PDB) with Plastic Standoff(x4). **Orient the PDB as shown with respect to frame.**

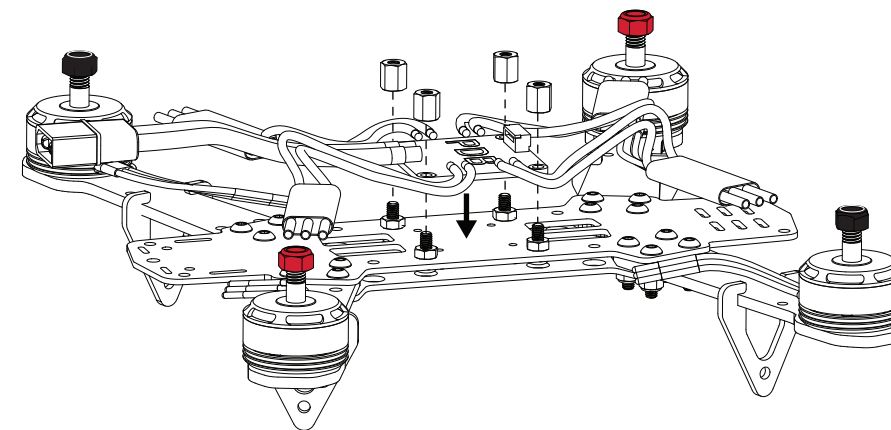

### 4

Connect ESCs to motor wires. Fasten ESCs and motor wires to arms with zip ties.

**Note:** Connect the three motor wires in any order at this time. Before the drone is flown the motors must be tested to ensure they are spinning in the correct direction according to Figure 3. If a motor is found to be spinning in the wrong direction simply swap any two of the three wires.

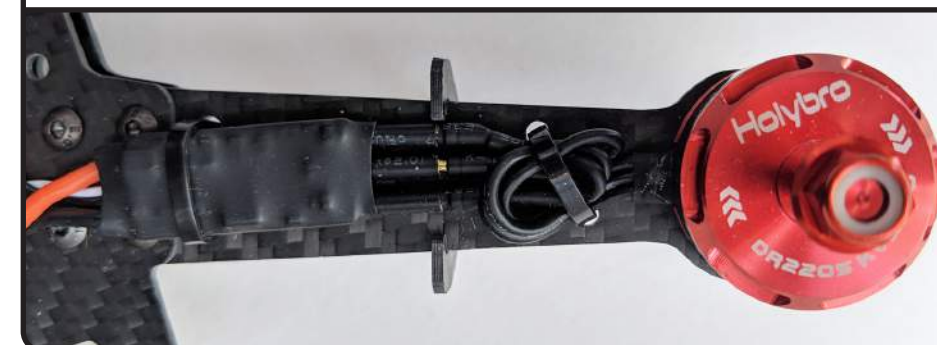

### 5

Connect ESC signal lines to MAIN OUT of the Pixhawk 4 Mini in the correct order indicated in Figure 3. **Orient connectors as shown.**



6

Secure wires to the frame with zip ties.

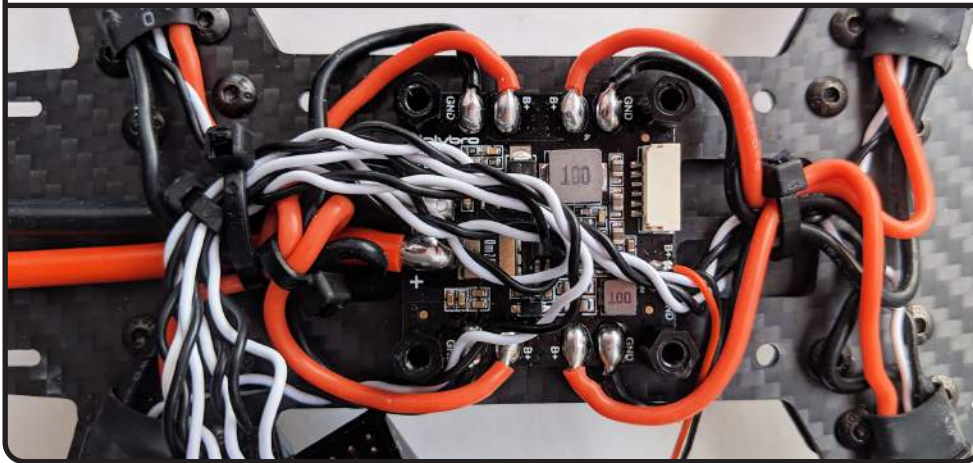

7

Fasten the Flight Controller Plate to the Plastic Standoffs with Plastic Flat Head Screw(x4).

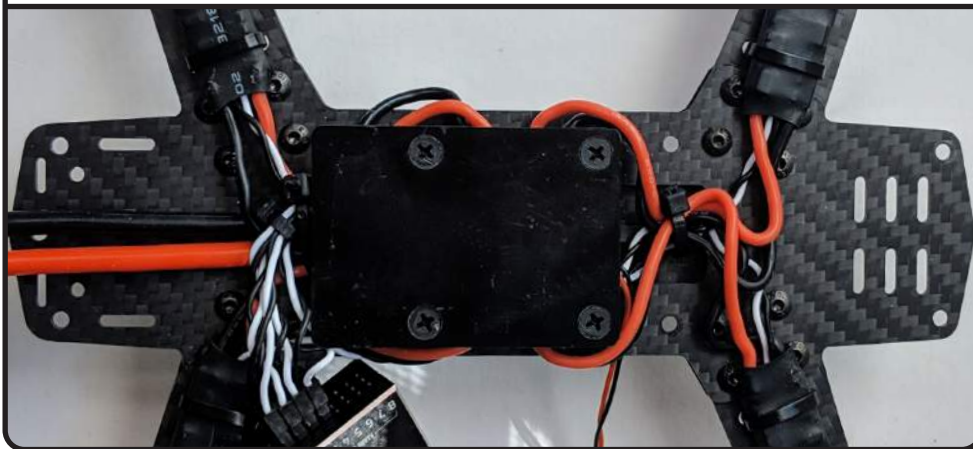

8

Stick foam pads on the Flight Controller Plate. Place the Pixhawk 4 Mini onto the foam pads. Press down firmly. **The arrow on the Pixhawk 4 Mini must point toward the front of the frame.**



9

Connect the Power Management Board to the POWER port of the Pixhawk 4 Mini using a 6-wire cable.

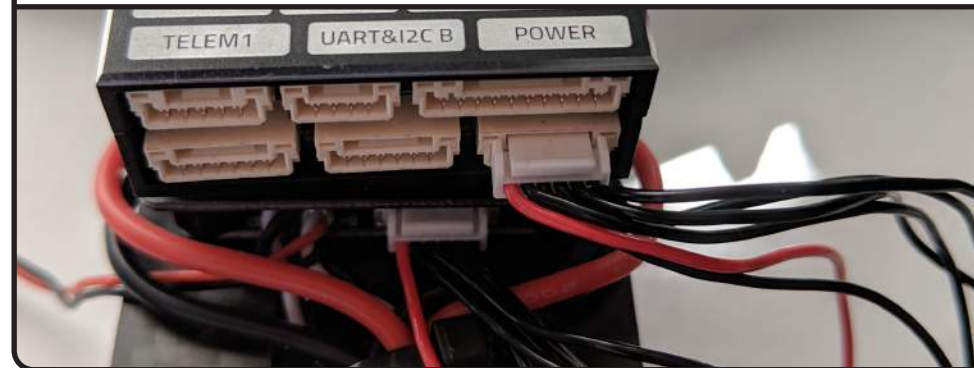

10

- a Connect the RC Receiver to the Pixhawk 4 Mini. If you have a PPM receiver connect to PPM port. If you have an SBUS receiver connect to RCIN.
- b **[Complete Kit]** Connect the FPV Transmitter to the FPV Power Board as shown in Figure 2.
- c Attach the RC Receiver and FPV Transmitter **[Complete Kit]** to the rear of the frame using a zip tie.

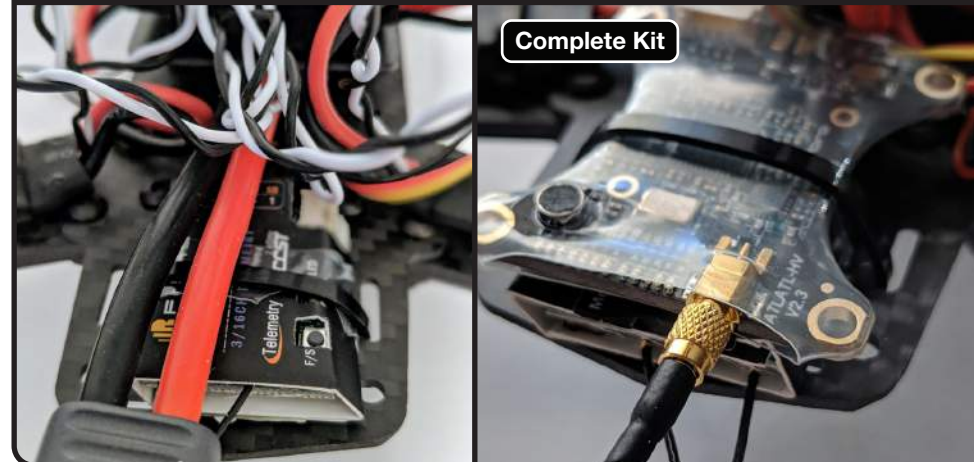

11

- a Connect the Mini Telemetry Radio to the Pixhawk 4 Mini TELEM port. I
- b **[Complete Kit]** Connect the FPV Power Board to the Pixhawk 4 Mini as shown in Figure 2.
- c Attach the Mini Telemetry Radio and FPV Power Board **[Complete Kit]** to the front of the frame using double sided tape.



12

[Complete Kit] Attach FPV Camera to Top Plate.

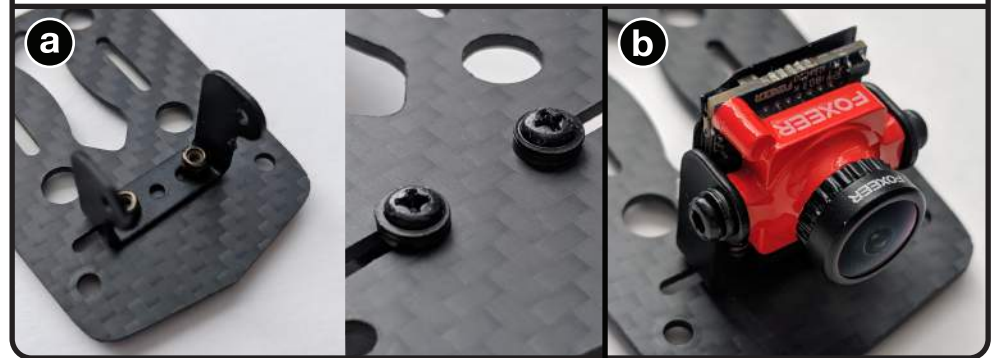

13

- a Attach 37mm Standoffs(x6) to Mid Plate with Steel M3 6mm Screws(x6).
- b **[Complete Kit]** Connect FPV Camera to FPV Power Board as shown in Figure 2.
- c Fasten down any loose wires to the frame with zip ties. The standoffs provide a good fastening point.
- d Attach the battery straps to the Top Plate. (Not shown. See Step 14.)
- e Loop GPS cable through Top Plate and connect the GPS to the Pixhawk 4 Mini GPS MODULE port.
- f Fasten the Top Plate to the Standoffs with Steel M3 6mm Screws(x6).
- g Attach the GPS to the Top Plate using the round foam pad and secure its cable to the frame with zip ties.

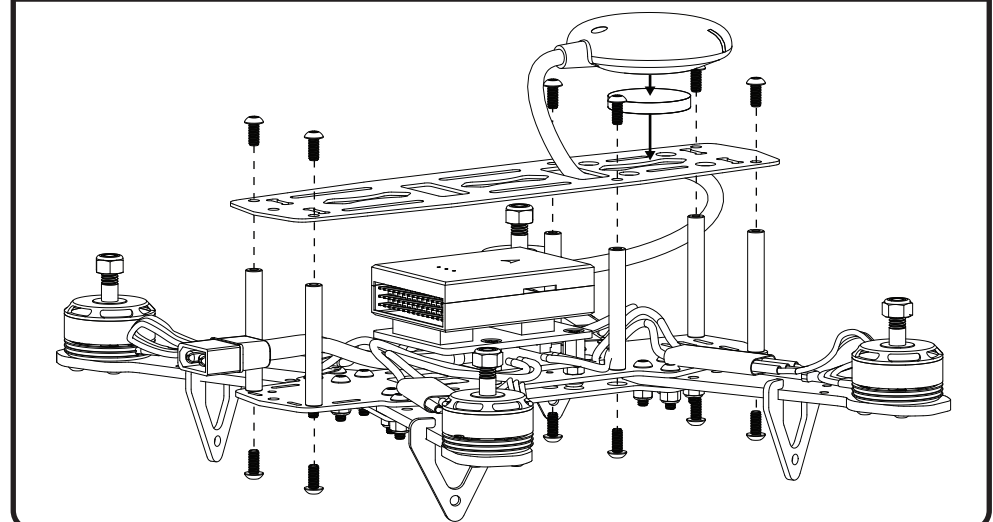

14

Please go to [https://docs.px4.io/en/frames\\_multicopter/holybro\\_qav250\\_pixhawk4\\_mini.html](https://docs.px4.io/en/frames_multicopter/holybro_qav250_pixhawk4_mini.html) to continue setting up your kit and configure PX4.

